



Picture may vary from actual product

## Turnstile.Gate ADA

Visitor-friendly and profitable at the same time:  
Extra wide gate for enhanced access security  
and convenience.

### Ultimate access convenience with motorized gates

- Entry is fully contactless – the turnstile arm is actuated automatically.
- Faster entry means less queuing for your guests and smoother visitor flow at your venue.

### A choice of intelligent options

- Extra wide entrances for simple, convenient access e.g. with wheelchair or stroller.
- Optimize visitor flow thanks to monitored sensor area.

### A class of its own

- Single-armed ADA compliant turnstiles offer flexible access management.
- Fast and secure access for up to 600 entries per hour.

### A perfect team player

- Go for perfect gate access by combining your three-armed Turnstile.Gates with a Turnstile.Gate ADA.
- Take advantage of this extra feature to enhance the convenience and security of all your visitors.

all dimensions in mm

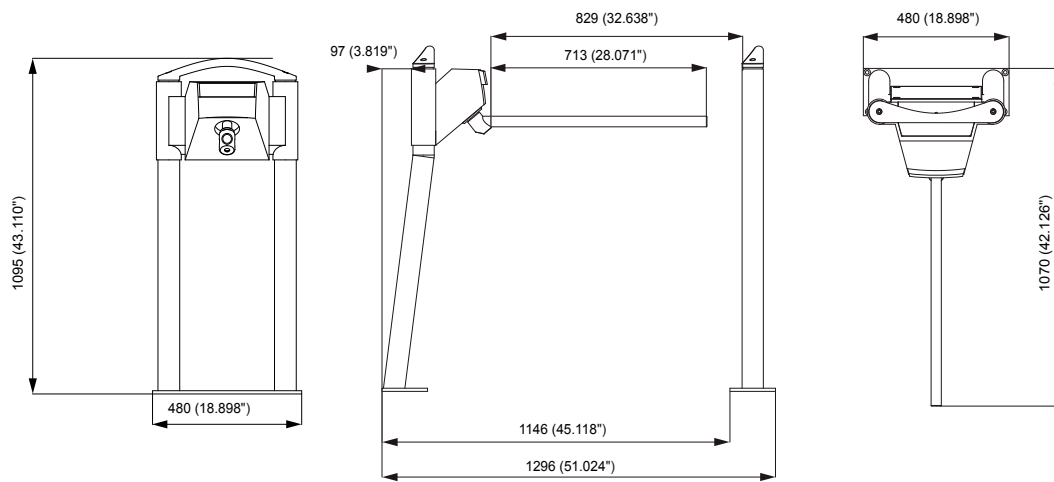

## Properties

### Range of applications

- Pedestrian access to stadiums, exhibition centers, visitor attractions etc.
- One-at-a-time admission and passage registration
- Person counter
- Suitable for indoor and outdoor use

### Features

- Low-maintenance, motor driven turnstile mechanism with electrical brake
- Torque control and overload protection
- Opto-electronic sensor and
- Extended opto-electronic sensor
- Hands-free turnstile opening movement upon release
- Turnstile arm is released in case of power failure

## Standard Version

- Servo turnstile unit, including hands-free sensor for Turnstile.Gate ADA
- Specially designed for people carrying luggage and persons with disabilities

### Accessories

- Floor stand (stainless-steel), disability-friendly
- Single-armed turnstile with fixed bar
- Shock absorbing protection cover for single-armed version
- Vario.Gate/FRMO/PWR240 power supply unit

## Options

- Floor-mount receptacle (for installation in raw concrete)
- Cover plate for floor-mount receptacle
- Railing, mountable on concrete flooring, on floor-mount receptacle or on palette; can be used as floor stand for mounting of Compact.Gate or Vario.Gate without Turnstile.Gate
- Single-armed turnstile with flexible bar, complete with shock absorbing protection cover

## Technical Specifications

<b>Dimensions</b>	480 mm x 1095 mm x 1070 mm / 18.9" x 43.11" x 42.13" (W x H x D)
<b>Weight</b>	Turnstile with floor stand and turnstile arm max. 27 kg Railing max. 15 kg
<b>Power supply</b>	24 V DC
<b>Power consumption</b>	max. 50 W
<b>Temperature range</b>	Operation: -30 °C to +40 °C (-22 °F to + 104 °F) Storage: -30 °C to +70 °C (-22 °F to + 158 °F)
<b>Housing color</b>	Die cast aluminum, RAL 9006
<b>Declarations / Certifications</b>	CE (incl. WEEE), <sub>c</sub> NRTL <sub>US</sub> optional, GOST-R, Ukr-Sepuro
<b>Safety note</b>	May only be used for manned entrances! Operation mode "free passage" is not allowed! The device is not designed for mass entrances!
<b>Degree of protection based on IEC 60529</b>	IP44